

Mooring systems

Mooring systems have been around just as long as man has felt the need for anchoring a vessel at sea. These systems were used, and are still used, on ships and consisted of one or more lines connected to the bow or stern of the ship. Generally the ships stayed moored for a short duration of time (days).

When the exploration and production of oil and gas started offshore, a need for more permanent mooring systems became apparent. Numerous different mooring systems have been developed over the years, of which a short selection is presented here.

Semi-submersible drilling rig - generally the semi-submersibles are moored using an eight point mooring. Two mooring lines come together at each of the columns of the semi-submersible.

CALM buoy - generally the buoy will be moored using four or more mooring lines at equally spaced angles. The mooring lines generally have a catenary shape. The vessel connects to the buoy with a single line and is free to weathervane around the buoy.

SALM buoy - these types of buoys have a mooring that consists of a single mooring line attached to an anchor point on the seabed, underneath the buoy. The anchor point may be gravity based or piled.

Turret mooring - this type of mooring is generally used on FPSOs and FSOs in more harsh environments. Multiple mooring lines are used, which come together at the turntable built into the FPSO or FSO. The FPSO or FSO is able to rotate around the turret to obtain an optimal orientation relative to the prevailing weather conditions.

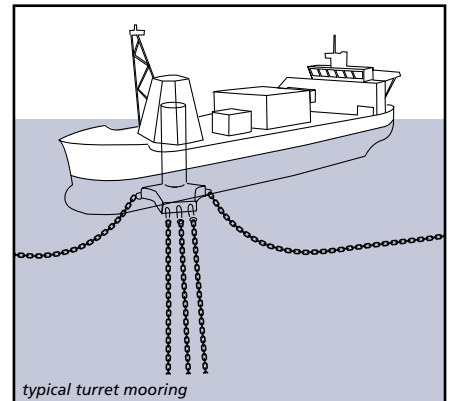
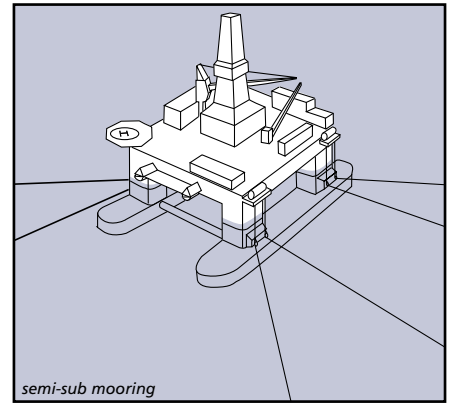

Spread mooring - generally used on FPSOs and FSOs in milder environments. The mooring lines are directly connected to the FPSO or FSO at both the stern and bow of the vessel.

When oil and gas exploration and production was conducted in shallow to deep water, the most common mooring line configuration was the catenary mooring line consisting of chain or wire rope. For exploration and production in deep to ultra-deep water, the weight of the mooring line starts to become a limiting factor in the design of the floater. To overcome this problem new solutions were developed consisting of synthetic ropes in the mooring line (less weight) and/or a taut leg mooring system (*fig. 1-01 and fig. 1-02*).

The major difference between a catenary mooring and a taut leg mooring is that where the catenary mooring arrives at the seabed horizontally, the taut leg mooring arrives at the seabed at an angle. This means that in a taut leg mooring the anchor point has to be capable of resisting both horizontal and vertical forces, while in a catenary mooring the anchor point is only subjected to horizontal forces. In a catenary mooring, most of the restoring forces are generated by the weight of the mooring line. In a taut leg mooring, the restoring forces are generated by the elasticity of the mooring line.

An advantage of a taut leg mooring over the catenary mooring is that the footprint of the taut leg mooring is smaller than the footprint of the catenary mooring, i.e. the mooring radius of the taut leg mooring will be smaller than the mooring radius of a catenary mooring for a similar application.

